

# **installation** instructions

WC Frame 1180mm with Dual Flush Cistern

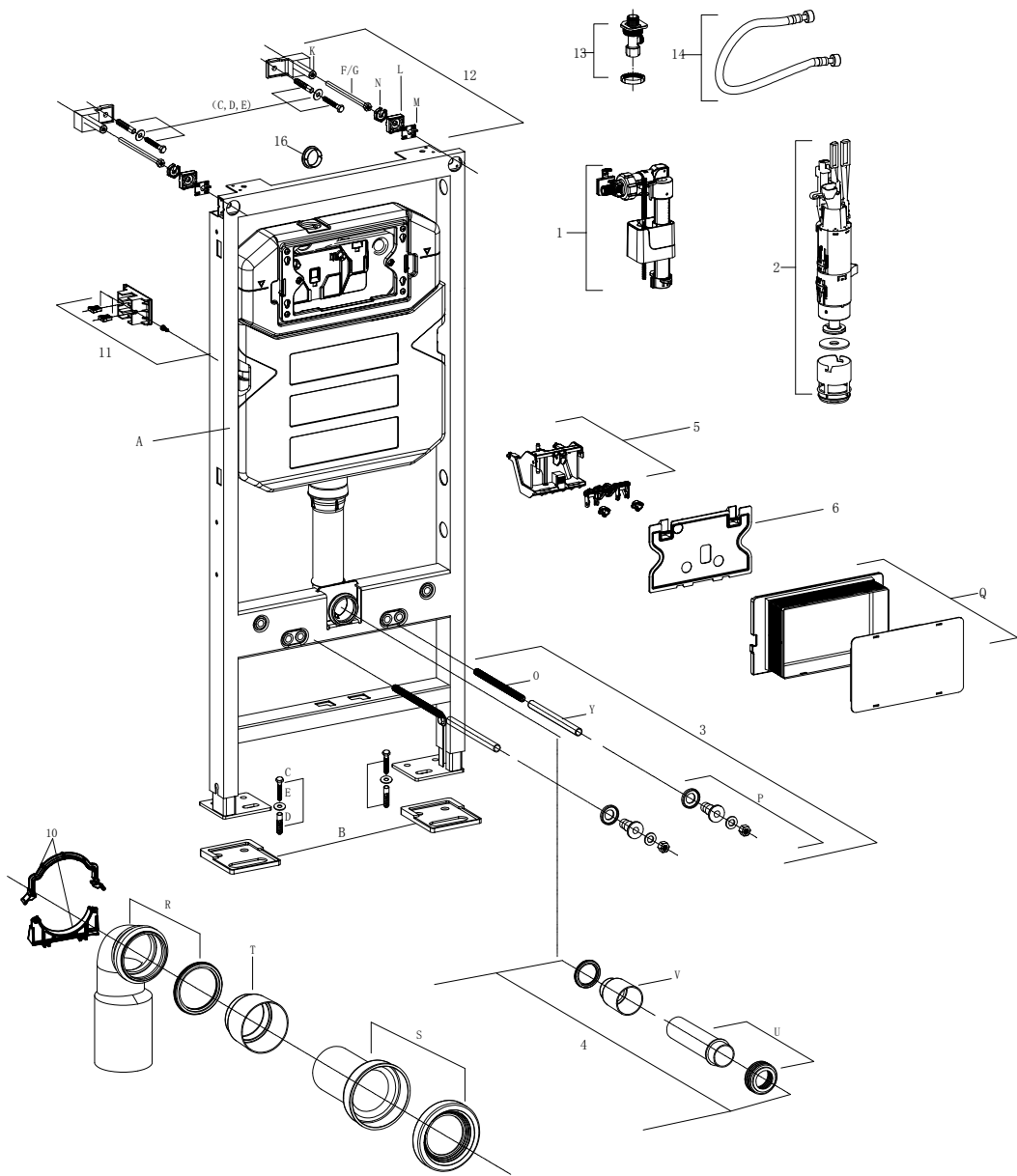















No.	Part no.	Description	Quantity
A		WC Frame with Dual Flush Cistern	1
B		Rubber Sound Deadening Pad for Feet	2
C		M6 x 65mm Coach Bolt	6
D		White Wall Plug 10mm	6
E		M6 Washer	6
F		M10 x 180mm Bolt	2
G		M10 x 110mm Bolt	2
H		M8 x30mm Bolt	2
I		M8 Washer	2
J		Unistrut Fixing	2
K		Wall Fixing Foot	2
L		Bolt Location Block	2
M		Bolt Retaining Clip	2
N		M10 Push Fit Fastening Nuts	2
O		Pan Fixing Bolt	2
P		Pan Fixing Nut	2
Q		Corrugated Tile Guide	1
R		Pan Connector	1
S		Soil Pipe Extension & Rubber Cone	1
T		Debris Stopper for Soil Pipe Extension	1
U		Flush Pipe Extension & Corrugated Rubber Cone	1
V		Debris Stopper for Flush Pipe Extension	1
W		Greased Sponge	1
Y		Clear Pan Fixing Bolt Shroud	1

### WC Frame incorporating:

No.	Part no.	Description	Quantity
1		Fill Valve	1
2		Dual Flush Siphon	1
3		WC Support Set	1
4		Pan and Flush Pipe Connector Set	1
5		Bracket	1
11		Cistern Mouting Bracket Set	2
12		Universal Wall Fixing Kit	1
13		Isolation Valve	1
14		Universal Filling Hose	1
15		Cistern Tile Guide	1

# Installation instructions

## Parts supplied

<b>A</b> 	<b>B</b> 	<b>C</b> 	<b>D</b> 	<b>E</b> 
1 x WC Frame with Dual Flush Cistern (incorporating Ball Valve, Siphon, Brass Inlet Valve)	2 x Rubber Sound Deadening Pad for Feet	6 x M6 x 65mm Coach Bolt	6 x White Wall Plug 10mm	6 x M6 Washer
<b>F</b> 	<b>G</b> 	<b>H</b> 	<b>I</b> 	<b>J</b> 
2 x M10 x 180mm Bolt	2 x M10 x 110mm Bolt	2 x M8 x 30mm Bolt	2 x M8 Washer	2 x Unistrut Fixing
<b>K</b> 	<b>L</b> 	<b>M</b> 	<b>N</b> 	<b>O</b> 
2 x Wall Fixing Foot	2 x Bolt Location Block	2 x Bolt Retaining Clip	6 x M10 Push Fit Fastening Nut	2 x Pan Fixing Bolt

P



2 x Pan Fixing Nut

Q



1 x Corrugated Tile Guide & Debris Stopper

R



1 x 90° Pan Connector

S



1 x Soil Pipe Extension & Rubber Cone

T



1 x Debris Stopper for Soil Pipe Extension

U



1 x Flush Pipe Extension & Corrugated Rubber Cone

V



1 x Debris Stopper for Flush Pipe Extension

W



1 x Greased Sponge

Y



2 x Clear Pan Fixing Bolt Shroud

## Tools required (not supplied)

- Tape Measure
- Level
- Pencil
- Electric Drill
- 10mm Drill Bit
- Screwdriver PH3
- Screwdriver PH2
- Large Straight Blade Screwdriver
- Spanner / Socket Set
- Hacksaw
- Retractable Blade Knife
- PTFE Tape

## Important Information

### **PLEASE READ THESE INSTRUCTIONS THOROUGHLY BEFORE STARTING INSTALLATION.**

Check the pack and make sure you have all the parts listed.

Remove all cardboard protection attached to the frame prior to installation.

All floor types need to be as flat and level as possible.

When drilling or fixing into walls or floor it is essential that you check for pipes or wires before commencing.

### **Site Preparation**

All floor types need to be clean, dry and dust free.

All floor types need to be as flat and level as possible.

Floor boards must be securely fixed down prior to installation.

## Adjusting the frame

The frame feet can be adjusted to allow for uneven floors and finished floor build up. The frame allows for an additional 280mm adjustment on the standard height. Using a spanner or socket, loosen the bolts just above the feet and extend the feet to your desired height. Ensure that the frame is square using a level before tightening the bolts using a socket or spanner.

## Before You Start

The first phase of installation is the securing of the frame to wall and floor. There are two methods of installation; either individual fixing or unistrut (rail) mounted fixing. The unistrut (rail) mounted system is normally used when fixing to stud walls rather than solid walls. Bypass Step 2 if you plan to individually fix the frame.

**Note:** The rail kit is an optional extra and can be purchased separately.

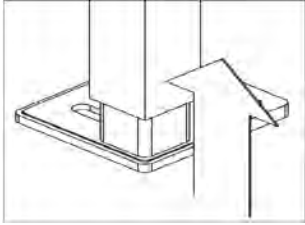
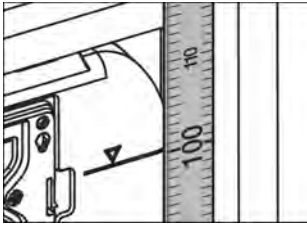

### Step 1

Set the frame so the mark on the cistern is 1000mm above floor level.

Ensure that the bolts are re-tightened when the desired height is achieved. The pan bolts can be set at either 180mm or 230mm centers.

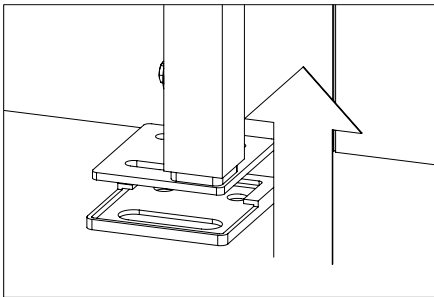

### Step 3

Fix the Rubber Sound Deadening Pads (B) to the Frame (A) feet. These help reduce noise transmission.

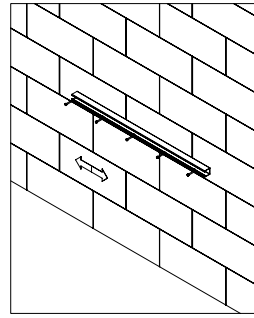

### Step 2

Ensure the rail is the correct length for the frames to be mounted. If necessary cut the rail to the required length using a hacksaw (standard sizes available are 1.08m, 1.8m & 3.0m).

Mark a horizontal line 80mm lower than the top of your frame using a pencil, i.e. if the frame is the standard height of 820mm, you should mark your horizontal line at 740mm.

Using the pencil line as the center point for the rail secure it to the wall using the fixings supplied, ensuring it is mounted evenly using a level.

**Note:** For individual installation please omit this step.

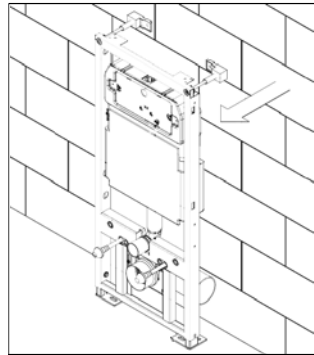

### Step 4

Space the frame off the back wall to the required distance. The minimum installation depth is determined generally by the width of the frame leg plus the services running behind the frame. A tolerance of 120 - 265mm from wall to front face of the frame can be achieved with standard 'in the box' parts.

**Note:** An extension set is available which offers a further 160mm and can be purchased from your merchant.

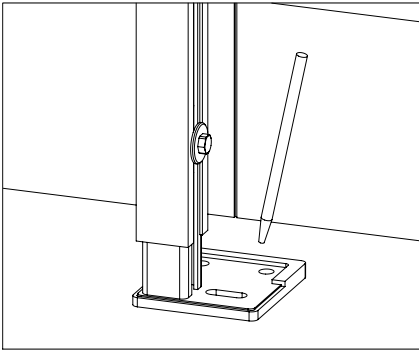

Mark through  
using a pencil

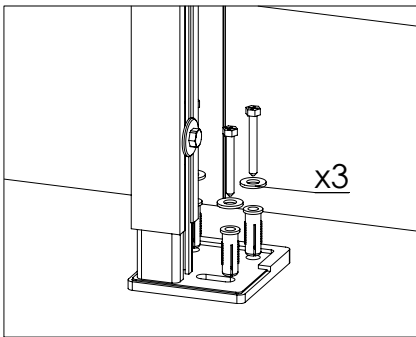

Solid floor application

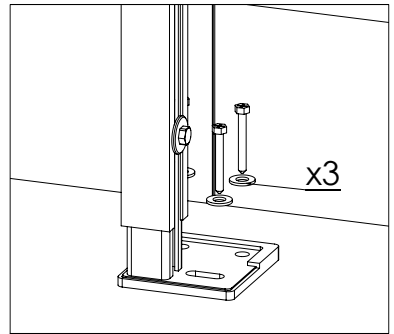

Timber floor application

### Step 5

Using a pencil, mark through the four holes in the Frame (A) feet the fixing hole positions.

#### Timber floor application

Secure the feet into position by fixing the four M6 x 65mm Coach Bolts (C) and four M6 Washers (E) using a PH3 Screwdriver or Spanner and the pencil marks as a guide.

In the event of the Coach Bolts (C) being unsuitable for your particular application, please replace these items with your choice of comparable fixing.

#### Solid floor application

Drill four holes in the floor using a drill and 10mm drill bit using the pencil marks as a guide. Insert the four 10mm White Wall Plugs (D) into the holes. Secure the feet into position by fixing the four M6 x 65mm Coach Bolts (C) and four M6 Washers (E) using a PH3 Screwdriver or Spanner and the Wall Plug locations as a guide.



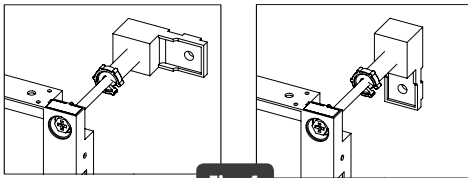
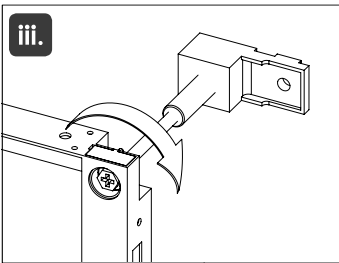
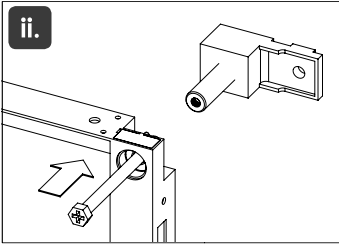
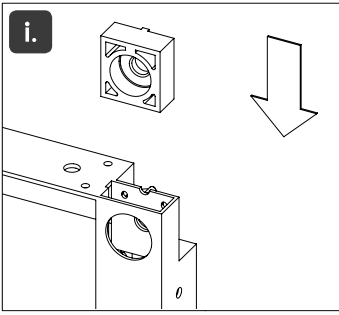

**Fig. 1**

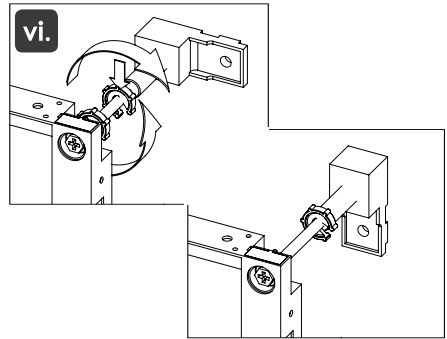
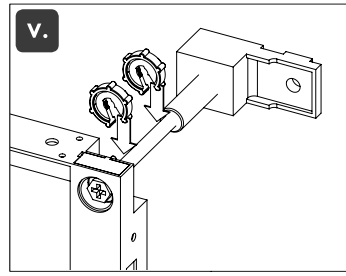
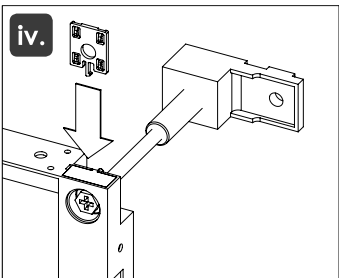

### Step 6

Place the two Bolt Location Blocks (L) into either side of the top frame profile.

Dependant on the depth required and measured in Step 4, take either the two M10 x 180mm Bolts (F) for a tolerance of 120 - 200mm, or the two M10 x 110mm Bolts (G) for a tolerance of 190 - 265mm and thread the two bolts (F) or (G) through the Bolt Location Blocks (L).

Fasten the two Wall Fixing Feet (K) to the bolts (F) or (G) to the desired depth measured in Step 4. The wall fixing feet can be fixed to the wall in a number of ways (See Fig. 1). Generally they should be installed with the screw hole pointing downwards for unistrut (rail) or individual fixing. However where achievable they can be installed with the screw holes pointing outwards for ease of fixing. Insert the two Bolt Retaining Clips (M) into either side of the top frame profile with the raised face to the front. This captivates the bolts whilst still allows for tightening with a straight bladed screwdriver as needed. Fit two M10 Push Fit Fastening Nuts (M) per bolt; the first at either end of the thread to lock the bolt into position.

Note: To achieve a minimum depth of 120mm you should only affix one M10 Push Fit Fastening Nut (M) per bolt and not two as instructed above.

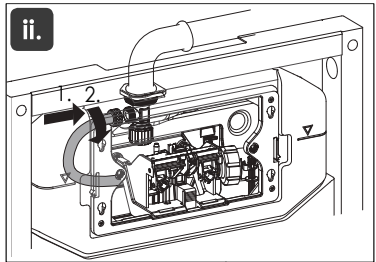
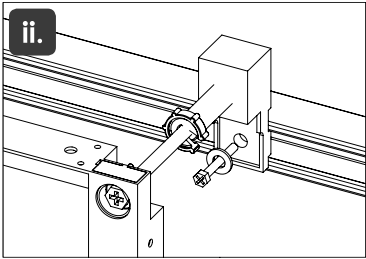
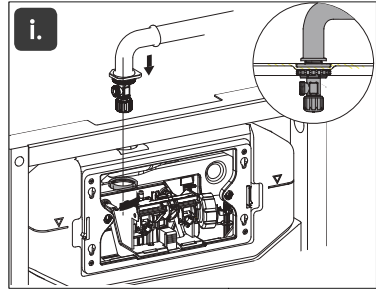
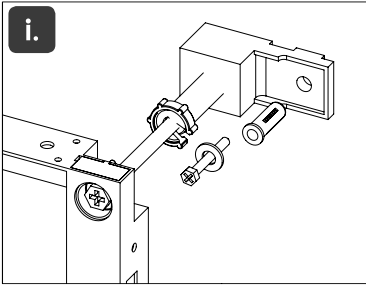

## Step 7

Using a pencil, mark through the two holes in the Wall Fixing Feet (K) the fixing hole positions.

### Solid wall fixing

Drill two holes in the wall using a drill and 10mm drill bit using the pencil marks as a guide. Insert the two 10mm White Wall Plugs (D) into the holes. Secure the feet into position by fixing the two M6 x 65mm Coach Bolts (C) and two M6 Washers (E) using a PH3 Screwdriver and the Wall Plug locations as a guide.

### Unistrut (Rail) Fixing

Insert the two unistrut fixings (J) into the unistrut (rail), then attach the Wall Fixing Feet (K) to the unistrut using one M8 x 30mm Bolt (H) and one M8 Washer (I) per Wall Fixing Foot (K).

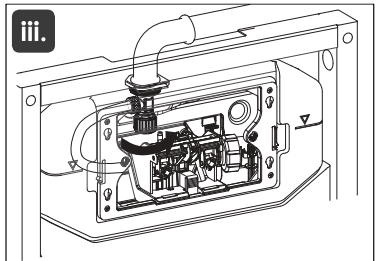

## Step 8

Connect the cold water connection to the Brass Water Inlet Valve pre-fixed to the Cistern wall using a thick layer of PTFE Tape.

Note: The Brass Water Inlet Valve has an integrated shut off valve and the water supply into the cistern can be isolated by a clockwise turn of the valve either using a straight bladed screwdriver or by hand.

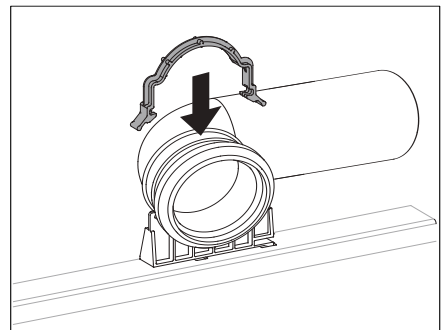
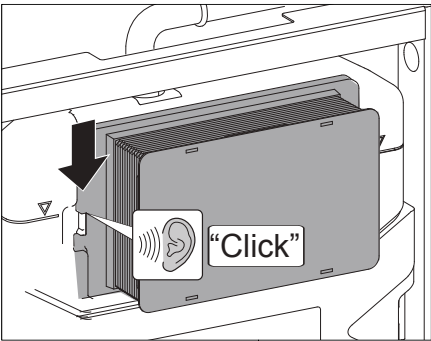
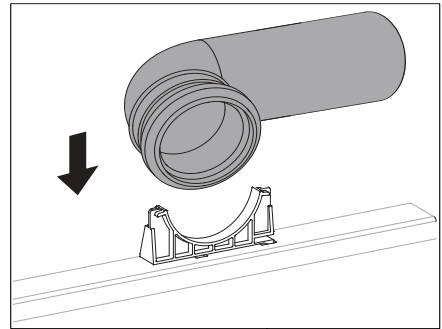
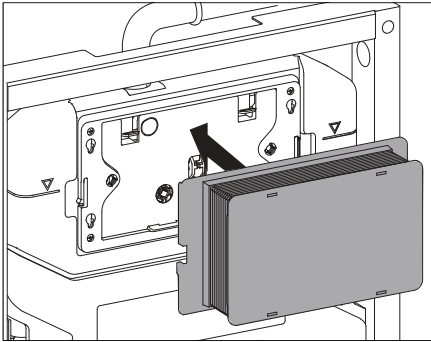
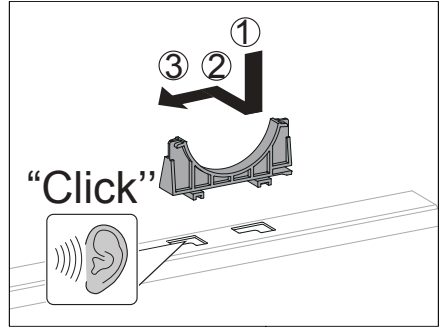
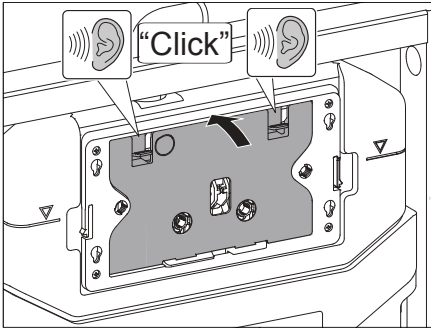

**Step 9**

Attach and secure the corrugated tile guide.

**Step 10**

To install the 90° Pan Connector (R). Offer the soil pipe to the clamp and secure using the clamp.

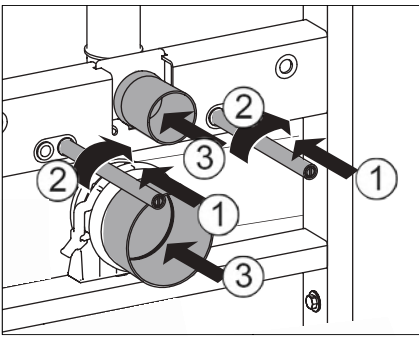

### Step 11

Connect the Debris Stopper for Flush Pipe Extension (V) and Debris Stopper for Soil Pipe Extension (T).

Attach the two Pan Fixing Bolts (O). These can be set to the appropriate length as set out by the WC pan manufacturer.

Install any other pre-wall frames as required and install either timber or metal studwork either side of the frame, before then plaster boarding and tiling.

**Note:** The frame comes with holes in either leg, which can be used to fix a screw into the studwork at either side for added strength as required.

**\* The frame is now ready for 2nd Fix Installation \***

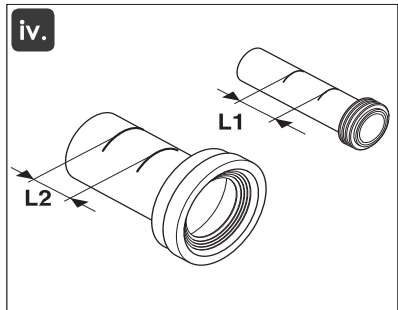
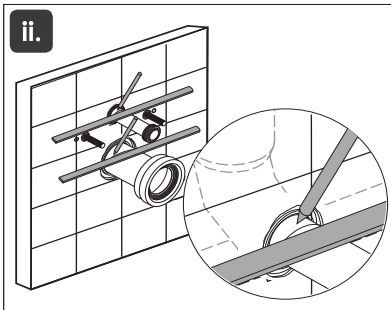
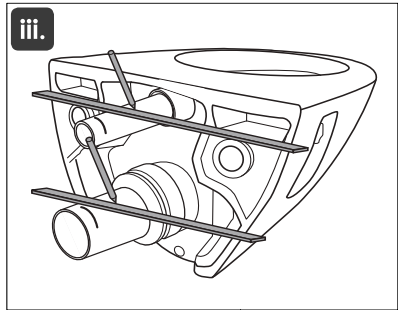
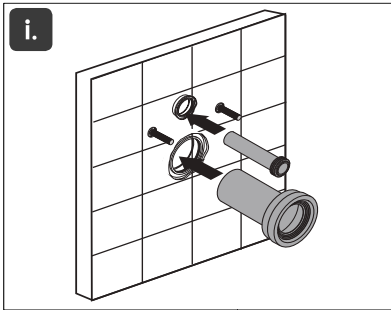

### Step 12

Discard the Debris Stopper for Flush Pipe Extension (V) and the Debris Stopper for Soil Pipe Extension (T). Apply grease liberally around the Cistern Flush Pipe and 90° Pan Connector (R) using the Greased Sponge (W).

### Step 13

Cut down the Flush Pipe Extension & Corrugated Rubber Cone (U) and Soil Pipe Extension & Rubber Cone (S) according to the WC pan being installed. If the two Pan Fixing Bolts (O) need any further adjustment they can be wound down to the desired length using a straight bladed screwdriver. Place the two Clear Pan Fixing Bolt Shrouds (Y) over the two Pan Fixing Bolts (O) and cut to suit the bolt length, allowing for the two Pan Fixing Nuts (P).

v.

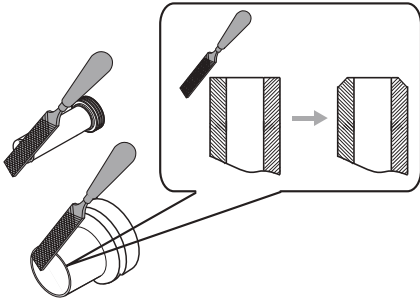

viii

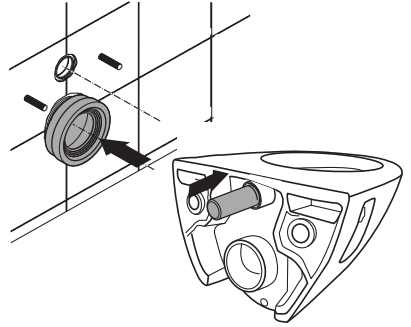

vi.

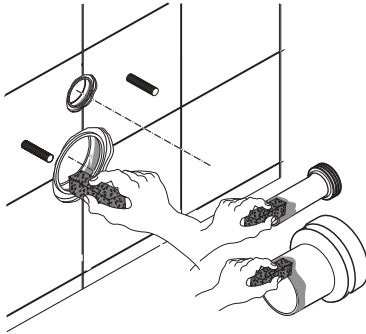

ix.

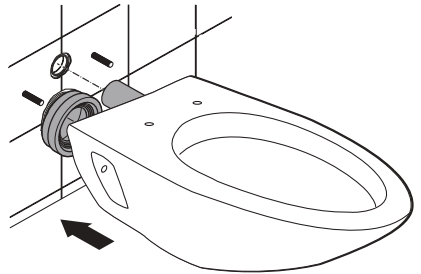

vii.

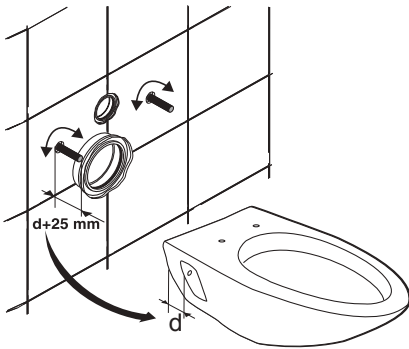

x.

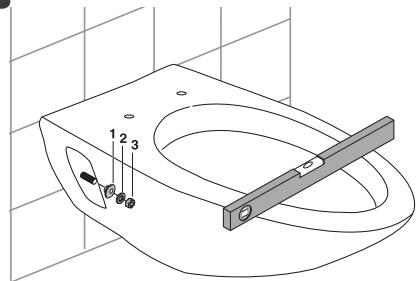

### Setting the flush volumes

Flush volumes are set by altering the ball valve float height and the two red sliding tabs on the flush syphon. The images below show the most common settings.

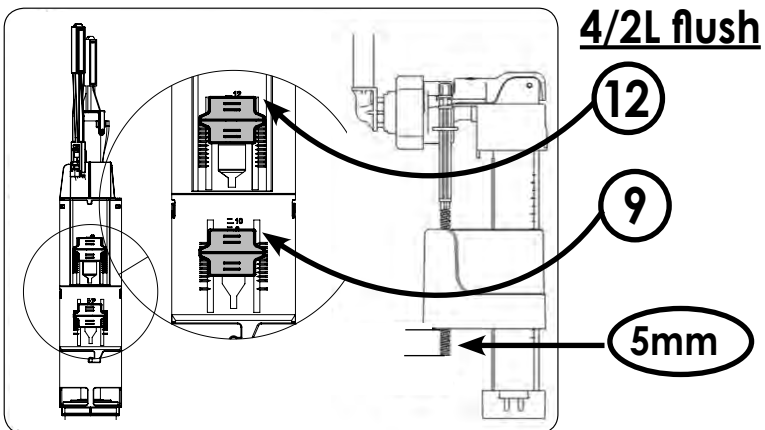
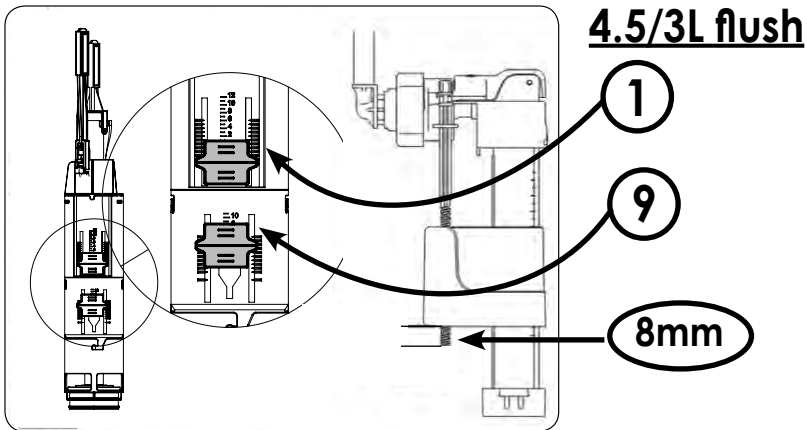
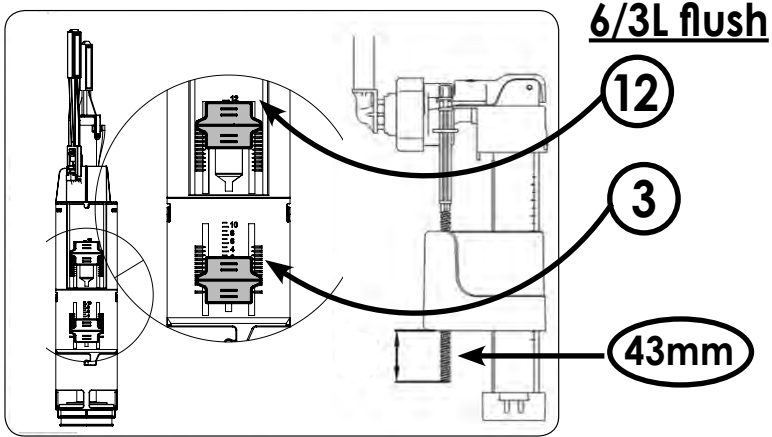



13

**EN 14055:2010**  
**K130 Cistern**

<b>Essential characteristics</b>	<b>Performance</b>	<b>Harmonised technical specification</b>
Watertightness/ Leaktightness	Pass	EN 14055:2010 Clause 5.2.8
Endurance	Pass	EN 14055:2010 Clause 5.2.9
Noise Level	I	EN 14055:2010 Clause 8
Flushing Volume	Pass (9)	EN 14055:2010 Clause 5.2.1
Durability	Pass	EN 14055:2010 Clause 5.2.11

For any further information please contact your merchant

The manufacturer reserves the right to make technical modifications without prior notice.

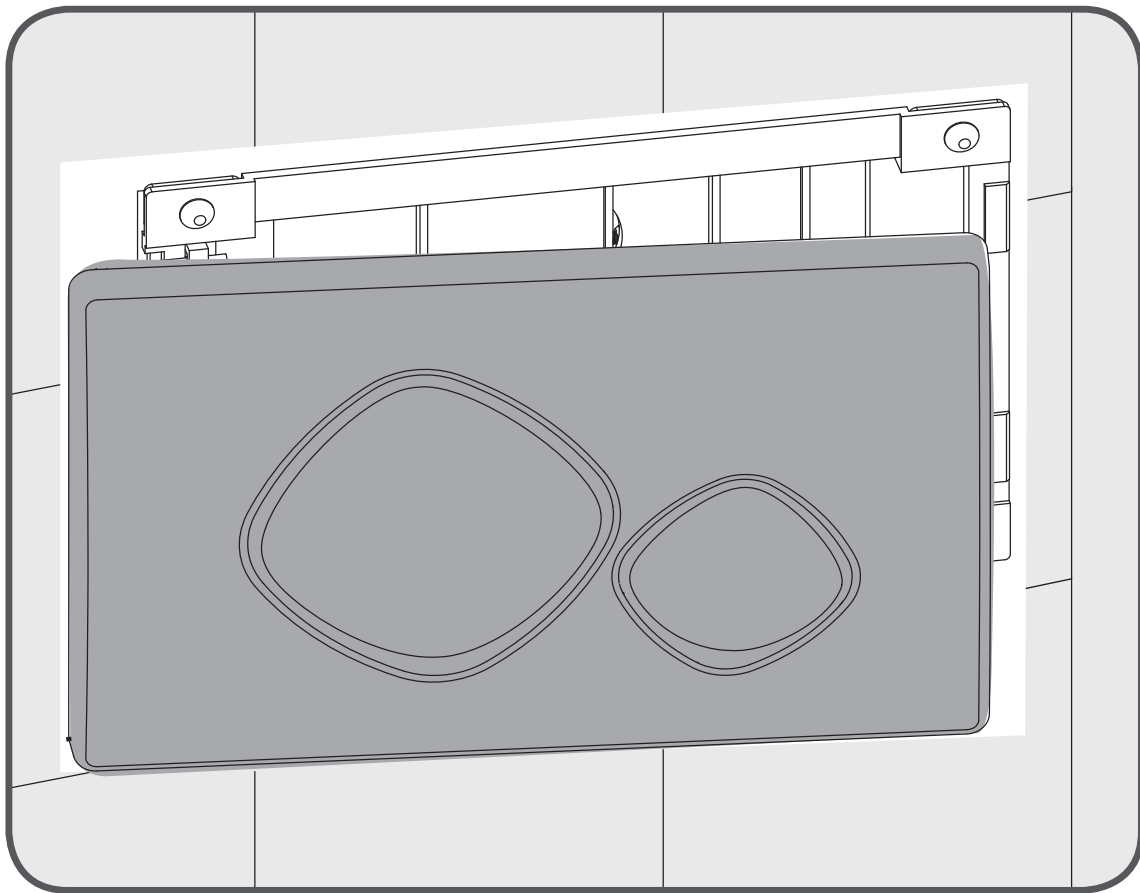

# **installation** instructions

Fitting Press Panels to  
0.82 / 0.98 / 1.18m WC Frames



The following fitting instructions cover all Press Panels and heights of frame.

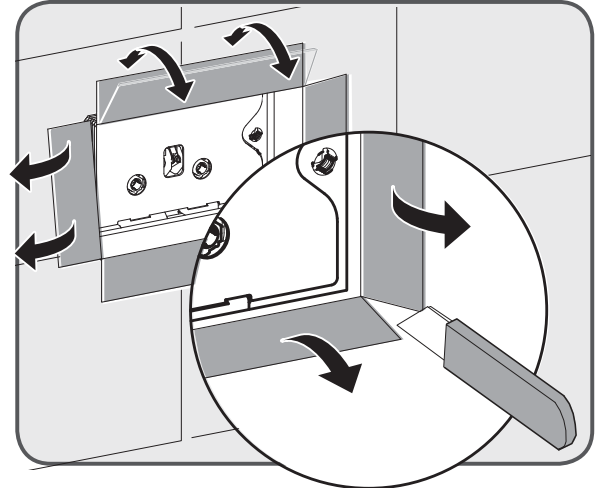
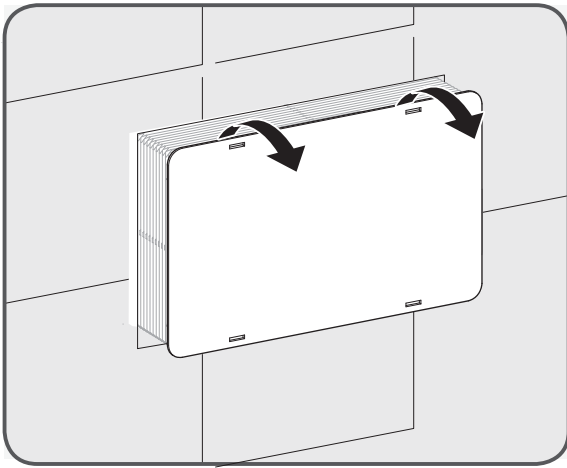

**Step 1**

Discard the blanking plate from Corrugated Tile Guide & Flush Plate Mount and cut down the Corrugated Tile Guide & Flush Plate Mount so that it is flush with the tile using a Retractable Blade Knife.

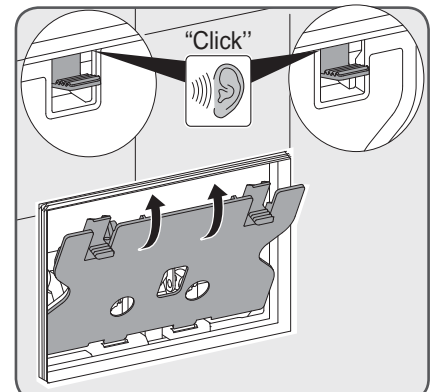
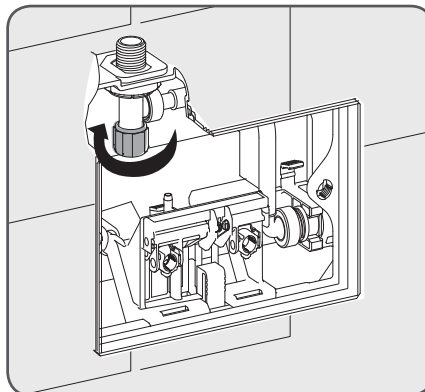
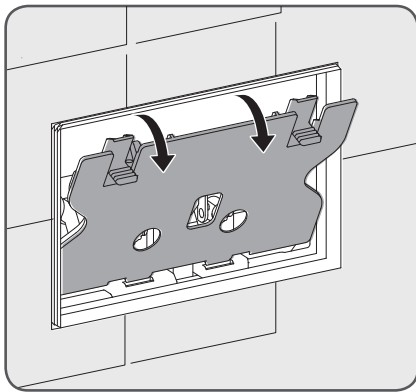

**Step 2**

Remove the cover plate. At this stage you can now activate the water supply to the frame at the isolation valve within the cistern either by hand or with a flat bladed screwdriver. Replace the cover plate. Ensure that it clicks back into place.

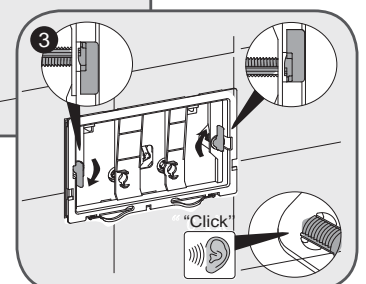
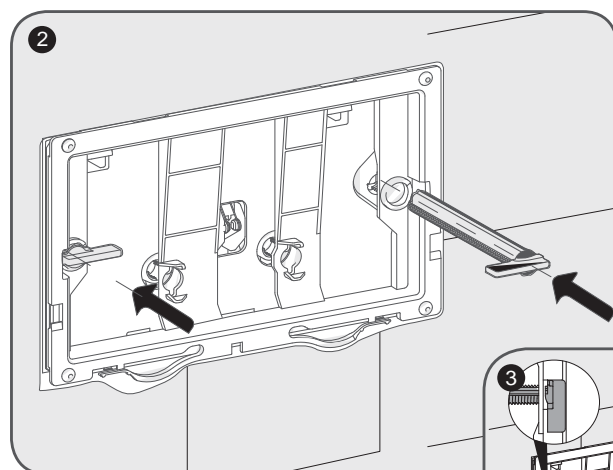
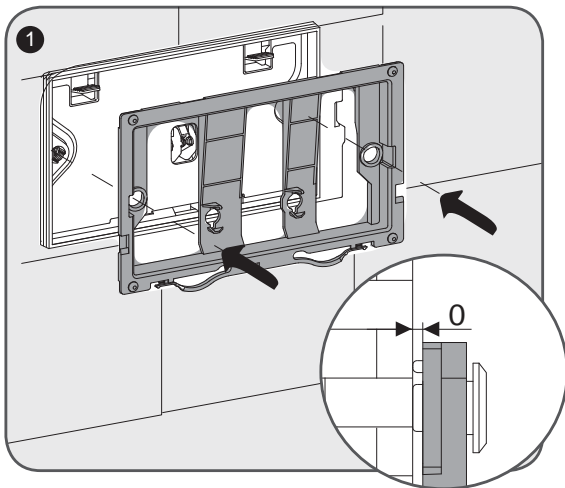

**Step 3**

Secure the Fixing Mount by inserting the Threaded Rod (G) and turning through 90° until the click is heard.

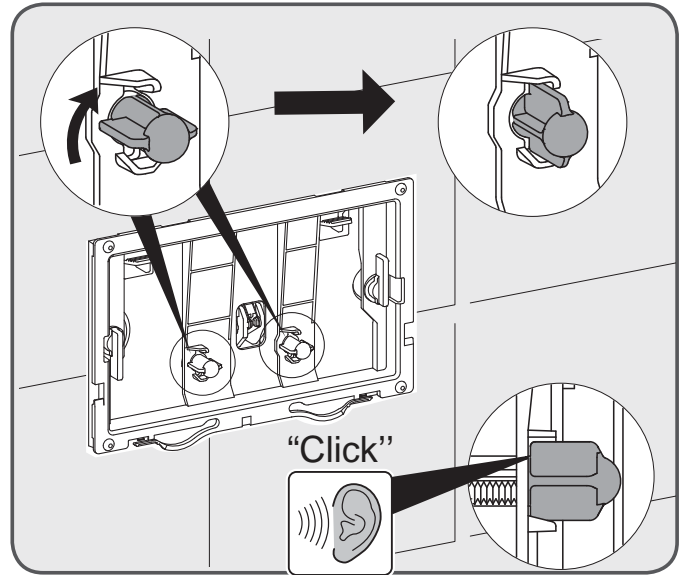
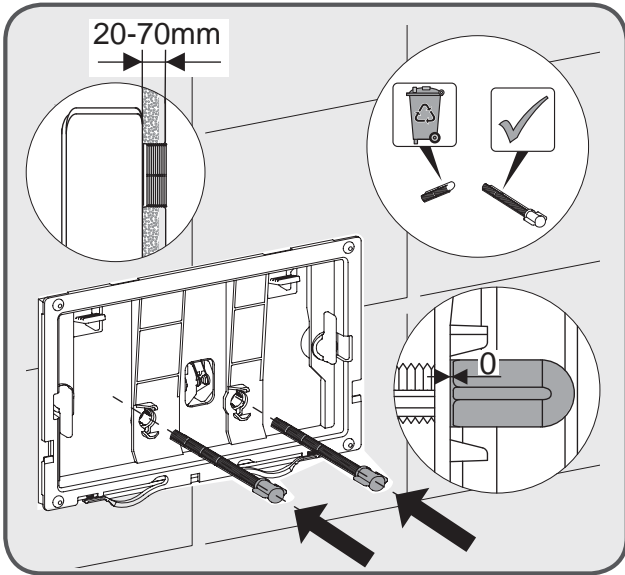

**Step 4**

Insert the Flush Push Rods fully un turn through 90° until the click is heard.

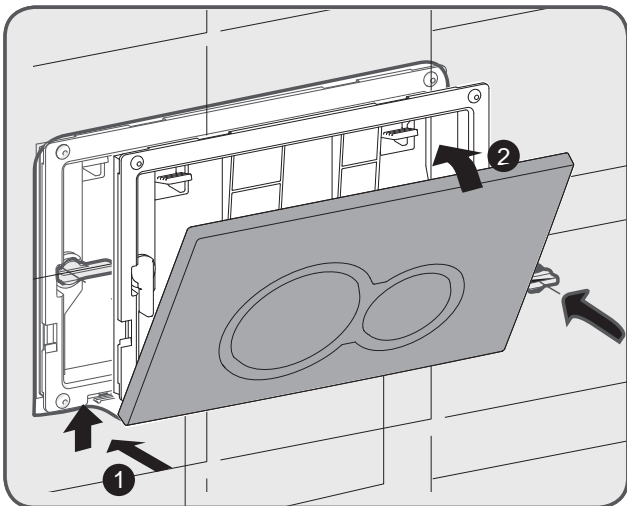

**Clip located at the bottom**

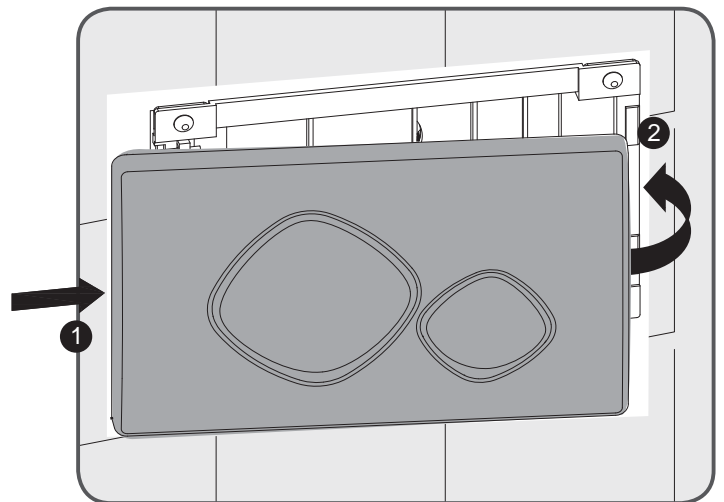

**Clip located to the left hand side**

**Step 5**

Hook the Press Panel over the Fixing Mount for Cistern and push gently so that it clips and holds in position. Depending on the fixing mount, the spring clip may be located on the base of the mount (as shown in these instructions) or to the left hand side; see images above for further details on how to clip the Press Panel in place.

**If you require any assistance or advice  
please contact your merchant.**